

FITTING INSTRUCTION

Clamp mark in acc. with		Cables joining
ISO	PN	
1	L	Left directional lights
2	+	Rear fog lights
3	31	Ground
4	R	Right directional lights
5	58R	Right side parking lights
6	54	Stoplights
7	58L	Left side parking lights

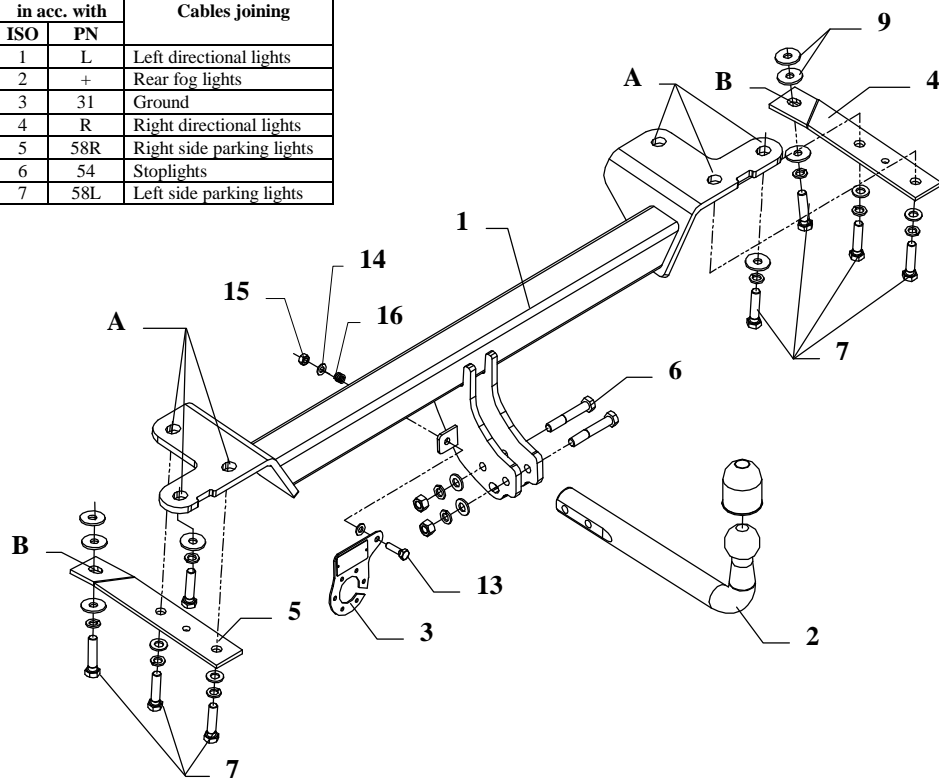

This towing hitch is designed to assembly in following cars:
SUZUKI VITARA, 5 door, produced since 2005, catalogue no. **W22** and is prepared to tow trailers max total weight **2000 kg** and max vertical load **85 kg**.

From manufacturer

Thank you for buying our product. Their reliability has been confirmed in many tests. Reliability of towing hitch depends also on correct assembly and right operation. For this reasons we kindly ask to read carefully this instruction and apply to hints.

The towing hitch should be install in points described by a car producer.

The instruction of the assembly

1. Disassemble the towing eye (the right side).
2. Disassemble the back silencer and slacken the thermal shield.
3. In the centre of the bumper (in axis) cut out fragment 65x80mm.
4. Apply the main bar of the towing hitch (pos. 1) and fish-plates (pos. 4 and 5) to chassis members that way, so holes (pos. A and B) agree with original made holes (threaded) and fix using bolts M12x1,25x50mm (pos. 7) and big washers $\varnothing 35 \times 13 \times 3$ mm (pos. 9).
5. Fix tow-ball (pos. 2) by bolts M12x70mm (pos. 6) from accessories.
6. Fix the socket plate (pos. 3) as shown on the drawing.
7. Tighten all bolts according to the torque shown in the table.
8. Connect electric wires of 7-poles socket according to the instruction of the car. (Recommend to make at authorized service station)
9. Complete paint layer damaged during installation.

Torque settings for nuts and bolts (8,8):	
M 8 - 25 Nm	M 10 - 55 Nm
M 12 - 85 Nm	M 14 - 135 Nm











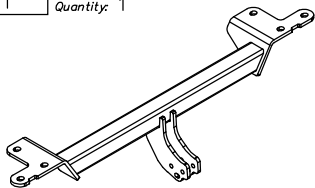
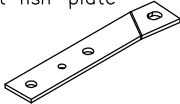

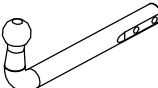
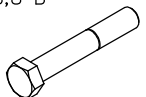
NOTE

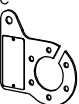
After install the towing hitch you should get adequate note in registration book (at authorised service station).The car should be equipped with:

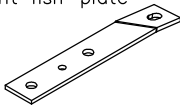
- Indicators
- Tow mirrors

After 1000km of exploitation check all bolts and nuts. The ball of towing hitch must be always kept clear and conserve with a grease.

Towing hitch accessories:

Pos. 1	Name: Main bar Quantity: 1	Pos. 5	Name: Left fish-plate Quantity: 1	Pos. 11	Name: Spring washer Quantity: 10 Dim.: ϕ 12,2 mm
					
Pos. 2	Name: Tow ball Quantity: 1	Pos. 6	Name: Bolt 8,8 B Quantity: 2 Dim.: M12x70mm	Pos. 12	Name: Ball cover Quantity: 1
					
Pos. 3	Name: Socket plate Quantity: 1	Pos. 7	Name: Bolt 8,8 B Quantity: 8 Dim.: M12x1,25x50mm	Pos. 13	Name: Bolt 8,8 B Quantity: 1 Dim.: M8x30mm
					
Pos. 4	Name: Right fish-plate Quantity: 1	Pos. 8	Name: Nut 8 B Quantity: 2 Dim.: M12	Pos. 14	Name: Plain washer Quantity: 2 Dim.: ϕ 8 mm
					
		Pos. 9	Name: Washer Quantity: 8 Dim.: ϕ 35x ϕ 12x3mm	Pos. 15	Name: Nut 8 B Quantity: 1 Dim.: M8
					
		Pos. 10	Name: Plain washer Quantity: 6 Dim.: ϕ 13 mm	Pos. 16	Name: Spring Quantity: 1
					



PPUH AUTO-HAK S.J.

Produkcja Zaczepów Kulowych
Henryk & Zbigniew Nejman
76-200 SŁUPSK ul. Słoneczna 16K
tel/fax (059) 8-414-414; 8-414-413
E-mail: office@autohak.com.pl
www.autohak.com.pl

Towing hitch (without electrical set)

Class: **A50-X** Cat. no. **W22**

Designed for:

Manufacturer: **SUZUKI**

Model: **VITARA**

Type: **5 door**

produced since 2005

Technical data:

D-value: 10,1 kN

maximum trailer weight: **2000 kg**

maximum vertical cup load: **85 kg**

Approval number according to Directive 94/20/EC: e20*94/20*0067*00

Foreword

This towing hitch is designed according to rules of safety traffic regulations. The towing hitch is a safety component and can be install only by qualified personnel. Any alteration or conversion of the towing hitch is prohibited and would lead to cancellation of design certification. Remove insulating compound and underseal from vehicle (if present) in the area of the matting surfaces of the towing hitch.

The vehicle manufacturer's specifications regarding trailer load and max. vertical cup load are decisive for driving, and values for the towing hitch cannot be exceeded.

D-value formula:

$$\frac{\text{Max trailer weight [kg]} \times \text{Max vehicle weight [kg]}}{\text{Max trailer weight [kg]} + \text{Max vehicle weight [kg]}} \times \frac{9,81}{1000} = D \text{ [kN]}$$