

FITTING INSTRUCTION

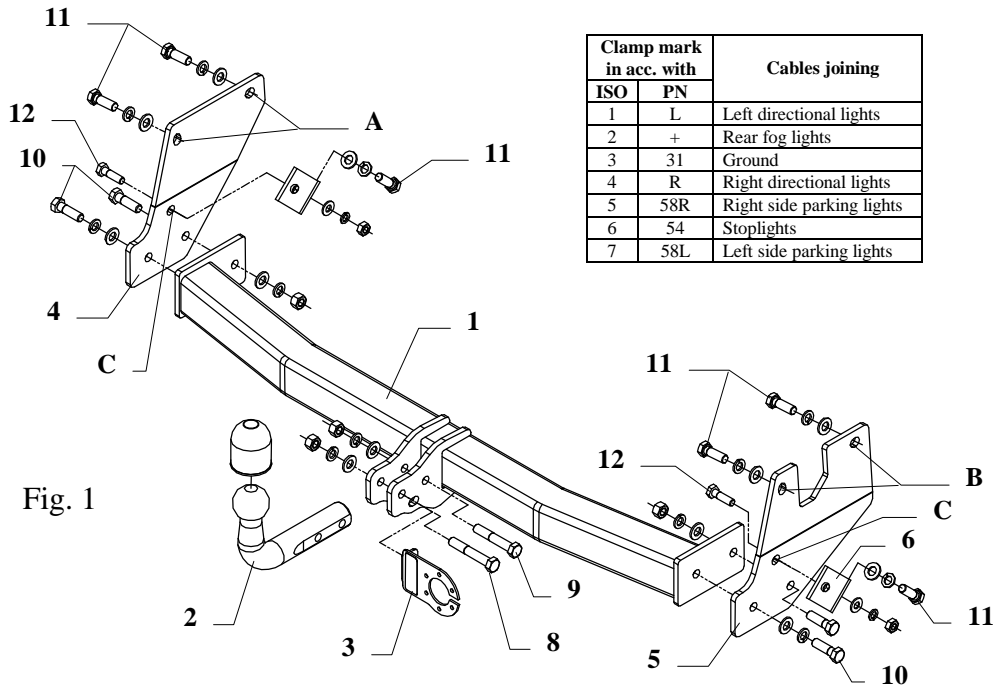

Clamp mark in acc. with		Cables joining
ISO	PN	
1	L	Left directional lights
2	+	Rear fog lights
3	31	Ground
4	R	Right directional lights
5	58R	Right side parking lights
6	54	Stoplights
7	58L	Left side parking lights

Fig. 1

This towing hitch is designed to assembly in following car:
TOYOTA HI-ACE 2WD and 4WD, produced since 08.1995 till 2002.,
 cat. no. **O61** and is prepared to tow trailers max total weight **2000 kg** and
 max vertical mass **75 kg**.

From manufacturer

Thank you for buying our product. Their reliability has been confirmed in many tests. Reliability of towing hitch depends also on correct assembly and right operation. For this reasons we kindly ask to read carefully this instruction and apply to hints.

The towing hitch should be installing in points described by a car producer.

Torque settings for nuts and bolts (8,8):
M 8 - 25 Nm **M 10 - 55 Nm**
M 12 - 85 Nm **M 14 - 135 Nm**

The instruction of the assembly

1. Take out the spare wheel and transport eyes on the left and right of the chassis (not used any more). Remove the spare wheel clamp and, if fitted, the safety holder. The removed bolts will not be used again.
2. Remove the spare wheel support bracket. Make the depressions straight. See figure 2.
3. Left side bracket (pos. 4) put on the outsider of the left chassis member and fix through holes pos. A by bolts M12x1.25x35mm (pos. 11). Right side bracket (pos. 5) put on inside of the right chassis member and fix through holes pos. B by bolts M12x1.25x35mm (pos. 11).
4. Fix handles (pos. 6) to chassis according to figure 1 using bolts M12x1.25x35mm (pos. 11) and next fix it to side brackets (pos. 4 and 5) through holes C using bolts M10x35mm (pos. 12).
5. Between mounted brackets (pos. 4 and 5) put main bar of towing hitch (pos. 1) and fix by bolts M12x 40mm (pos. 10).
6. In the spare wheel clamp replace original distance sleeve for sleeve from towing hitch accessories (pos. 14). To reinstall the clamp use bolt M12x140mm (pos. 7) from accessories. Reinstall (if fitted) the safety holder using original sleeve from clamp and bolt M8x50mm (pos. 13) from towing hitch accessories. See fig. 3
7. Fix tow-ball (pos. 2) together with socket plate (pos. 3) by bolts M12x75mm (pos. 8) and M12x70mm (pos. 9) from accessories.
8. Tighten all bolts according to the torque shown in the table.
9. Connect electric wires of 7-poles socket according to the instruction of the car. (Recommend to make at authorized service station).
10. Complete paint layer damaged during installation.

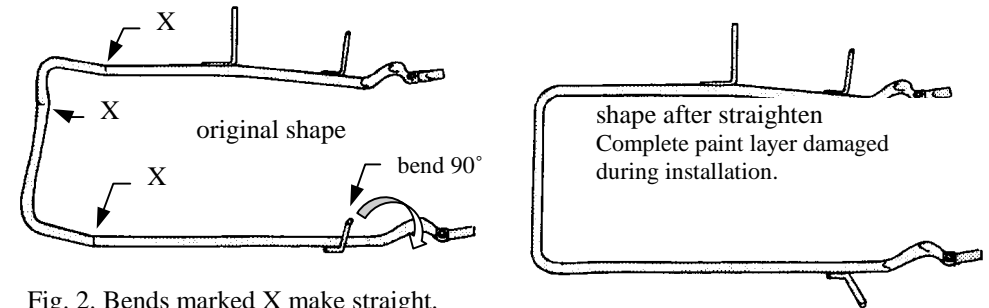

Fig. 2. Bends marked X make straight.

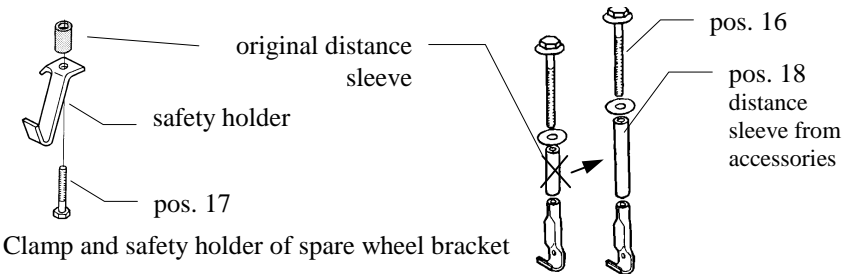

Fig. 3. Clamp and safety holder of spare wheel bracket

Towing hitch accessories:

Pos. 1 Main bar PCS.: 1	Pos. 6 Handle PCS.: 2	Pos. 12 Bolt 8,8 B M10x35mm PCS.: 2	Pos. 18 Spring washer ø10mm PCS.: 2
Pos. 2 Tow ball PCS.: 1	Pos. 7 Bolt 8,8 B M12x140mm PCS.: 1	Pos. 13 Bolt 8,8 B M8x50mm PCS.: 1	Pos. 19 Nut 8 B M12 PCS.: 4
Pos. 3 Socket plate PCS.: 1	Pos. 8 Bolt 8,8 B M12x75mm PCS.: 1	Pos. 14 Distance sleeve ø20xø13 L=93mm PCS.: 1	Pos. 20 Nut 8 B M10 PCS.: 2
Pos. 4 Left bracket PCS.: 1	Pos. 9 Bolt 8,8 B M12x70mm PCS.: 1	Pos. 15 Plain washer ø12mm PCS.: 12	Pos. 21 Ball cover PCS.: 1
Pos. 5 Right bracket PCS.: 1	Pos. 10 Bolt 8,8 B M12x40mm PCS.: 4	Pos. 16 Plain washer ø10mm PCS.: 2	
	Pos. 11 Bolt 8,8 B M12x1.25x35mm PCS.: 6	Pos. 17 Spring washer ø12mm PCS.: 12	

NOTE

After install the towing hitch you should get adequate note in registration book (at authorised service station). The car should be equipped with:

- Indicators
- Tow mirrors

After 1000km check all bolts and nuts. The ball of towing hitch must be always kept clear and conserve with a grease.



PPUH AUTO-HAK S.J.

Produkcja Haków Holowniczych
Henryk & Zbigniew Nejman
76-200 SŁUPSK ul. Słoneczna 16K
tel/fax (059) 8-414-414; 8-414-413
E-mail: office@autohak.com.pl
www. autohak.com.pl

Towing hitch (without electrical set)

Class: **A50-X** Cat. no. **O61**

Designed for:

Manufacturer: **TOYOTA**

Model: **HI-ACE**

produced since 08.1995 till 2002

Technical data:

D-value: 11,9 kN

maximum trailer weight: **2000 kg**

maximum vertical cup mass: **75 kg**

Approval number according to Directive 94/20/EC:

Foreword

This towing hitch is designed according to rules of safety traffic regulations. The towing hitch is a safety component and can be install only by qualified personnel. Any alteration or conversion of the towing hitch is prohibited and would lead to cancellation of design certification. Remove insulating compound and underseal from vehicle (if present) in the area of the matting surfaces of the towing hitch.

The vehicle manufacturer's specifications regarding trailer load and max. vertical cup mass are decisive for driving whereat values for the towing hitch cannot be exceeded.

D-value formula:

$$\frac{\text{Max trailer weight [kg]} \times \text{Max vehicle weight [kg]}}{\text{Max trailer weight [kg]} + \text{Max vehicle weight [kg]}} \times \frac{9,81}{1000} = D \text{ [kN]}$$